



Wincom Tech CO., LTD.

The LCD(M) Specialist

CONTACT ADDRESS: 6F, Block 105, Jing Di Industrial Park,
Fu Qiang Rd. Fu Tian, Shenzhen City, China.

Tel: 0086-755-83308729

Fax: 0086-755-83308659

E-mail: craig.jiang@wincomlcd.com



RoHS

PART NO. : WG12864D V1.0
 -STBLWHTC06

FOR MESSRS. : _____

CONTENTS

<i>NO.</i>	<i>ITEM</i>	<i>PAGE</i>
1.	COVER	1
2.	RECORD OF REVISION	2
3.	GENERAL SPECIFICATION	3
4.	MECHANICAL DATA	3
5.	ABSOLUTE MAXIMUM RATINGS	4
6.	ELECTRICAL CHARACTERISTICS	5
7.	OPTICAL CHARACTERISTICS	5
8.	OUTLINE DIMENSION	6~7
9.	BLOCK DIAGRAM	7
10	INTERFACE TIMING CHART	8-9
11	INSTRUCTION CODE	10

ACCEPTED BY: _____

PROPOSED BY: _____

RECORD OF REVISION

DATE	PAGE	SUMMARY

3. General specifications

3.1 General specifications

PLEASE REFER TO:

“CUSTOMER ACCEPTANCE STANDARD SPECIFICATIONS (MS-10-10000)”.

3.2 Quality Assurance and Warranty

PLEASE REFER TO:

“QUALITY ASSURANCE MANUL (MS-10-10001)”.

3.3 This individual specification is prior to general specifications

4. Mechanical data

- Display format: 128 x 64 DOTS
- LCD type: STN Negative , Blue
- Backlight color: White
- Viewing angle: 6:00
- Data transfer: 8Bit Parallel
- LCD controller: S6B0108
- Module size: 75x53 mm
- View area: 60 x 32.4 mm
- Dot size: 0.4 x 0.4 mm
- Dot pitch: 0.43 x 0.43mm
- Driving method: 1/64duty, 1/9 bias

5. Absolute maximum ratings

5.1 Electrical absolute maximum ratings

<i>I T E M</i>	<i>SYMBOL</i>	<i>MIN.</i>	<i>MAX.</i>	<i>UNIT</i>	<i>COMMENT</i>
POWER SUPPLY FOR LOGIC	V _{DD} -V _{SS}	-0.3	5.5	V	-----
INPUT VOLTAGE	V _I	V _{SS}	V _{DD}	V	-----
STATIC ELECTRICITY	-----	-----	-----	V	-----
POWER SUPPLY FOR BACKLIGHT	V _S	-0.3	3.3	V _{rms}	-----
	f _{FL}	-----	-----	KHz	-----
STARTING VOLTAGE FOR BACKLIGHT	-----	-----	-----	V _{rms}	Ta = 25°C
	-----	-----	-----	V _{rms}	Ta = 25°C
POWER SUPPLY FOR LCD	V _{lcd}	-----	10.2	V	-----

5.2 Environmental absolute maximum ratings

<i>I T E M</i>	<i>OPERATING</i>		<i>STORAGE</i>		<i>COMMENT</i>
	<i>MIN.</i>	<i>MAX.</i>	<i>MIN.</i>	<i>MAX.</i>	
AMBIENT TEMPERATURE	-20°C	70°C	-30°C	80°C	-----
HUMIDITY	NOTE (2)		NOTE (2)		NO CONDENSATION
VIBRATION NOTE (3)	-----	0.5G	-----	2G	10~300Hz XYZ DIRECTIONS 1 Hr EACH
SHOCK NOTE (3)	-----	3G	-----	5G	10 msec XYZ DIRECTIONS 1 TIME EACH
CORROSIVE GAS	NOT ACCEPTABLE		NOT ACCEPTABLE		-----

NOTE (2): Ta ≦ 70°C: 75% RH MAX.

Ta > 70°C: ABSOLUTE HUMIDITY MUST BE LOWER THAN THE HUMIDITY OF
75% RH AT 70°C.

NOTE (3): 1G = 9.8 m/s²

6. Electrical characteristics

Ta = 25°C VDD = 5.0V

<i>I T E M</i>	<i>SYMBOL</i>	<i>CONDITION</i>	<i>MIN.</i>	<i>TYP.</i>	<i>MAX.</i>	<i>UNIT</i>
Power supply voltage for circuit	VDD-VSS	-----	4.75	5.0	5.25	V
Power supply voltage for LCD drive	VDD-VEE	-----	-----	8.5	-----	V
Data input voltage	V _{IH}	H LEVEL	2.4	-----	V _{DD}	V
	V _{IL}	L LEVEL	-0.3	-----	0.4	V
LCD display duty ratio	DUTY	-----	-----	1/64	-----	-----
LED BACKLIGHT	I _{fp}	I mse0 plus 10% Dutg cycle		--		mA
		Operating voltage	3.0	3.1	3.2	V
		Forward current		60	100	mA
LED Lifetime	-----	V _{FL} = 3.1Vrms f _{FL} = KHZ	-----	100,000	-----	Hr

NOTE: LED backlight: Due to the LED backlight working current is XXX Max, and LED chips Vop may be different, Wincom will adjust the backlight resistor according to the LED chips Vop, to meet the brightness maximum.

7. Optical characteristics

Ta = 25°C VLCD = 8.5V

<i>I T E M</i>	<i>SYMBOL</i>	<i>CONDITION</i>	<i>MIN.</i>	<i>TYP.</i>	<i>MAX.</i>	<i>UNIT</i>	<i>NOTE</i>
Viewing angle	Φ2-Φ1	K ≥ 2.0	-35	-----	20	deg.	1
Contrast ratio	K	Φ = 10° θ = 0°	4.0	-----	-----	-----	1
Response time (at 25°C)	tr (rise)	Φ = 10° θ = 0°	-----	-----	250	ms	1
	tf (fall)	Φ = 10° θ = 0°	-----	-----	250	ms	1
The brightness of backlighting source	B	V _{FL} = 3.1Vrms f _{FL} = KHZ	-----	250	-----	cd/m ²	2

NOTE (1): SEE CUSTOMER ACCEPTANCE STANDARD SPECIFICATION FOR DEFINITION OF OPTICAL CHARACTERISTICS

NOTE (2): UNDER NORMAL TEMPERATURE AND HUMIDITY IN A DARK ROOM

8. Outline dimension

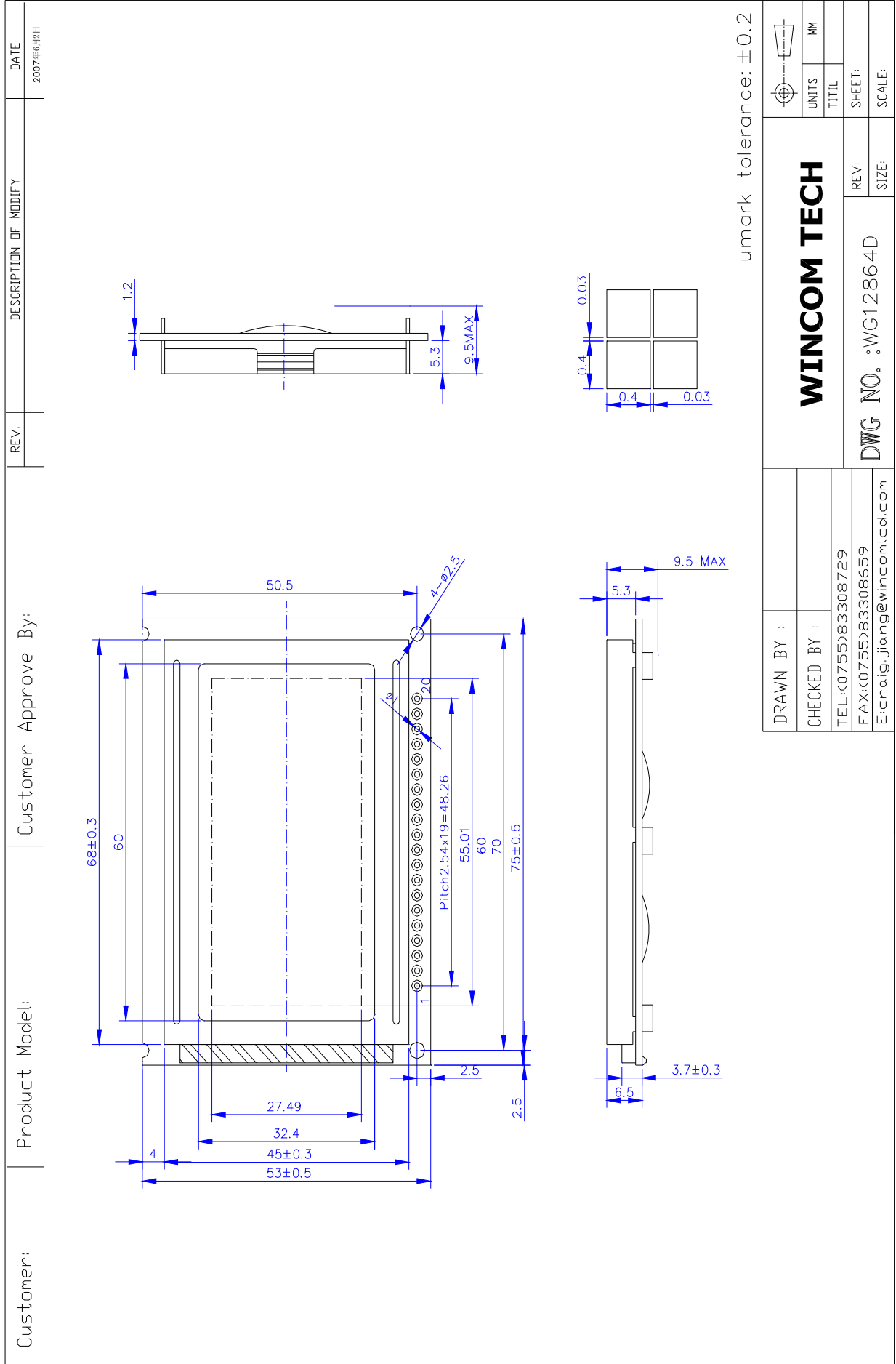

DRAWN BY :		WINCOM TECH	UNITS	MM
CHECKED BY :			TITL	
TEL: (0755) 83308729		DWG NO.: WG12864D	SHEET:	
FAX: (0755) 83308659			REV:	
E: craig.jiang@wincomtc.com			SCALE:	

8.2 Interface

Pin Assignment

PIN NO.	Symbol	Leve	Function
1	VDD	5.0V	Power supply for logic circuit
2	Vss	0V	Ground
3	V0	----	Contrast Adjust
4	DB0	H/L	Data Bus Line
5	DB1	H/L	Data Bus Line
6	DB2	H/L	Data Bus Line
7	DB3	H/L	Data Bus Line
8	DB4	H/L	Data Bus Line
9	DB5	H/L	Data Bus Line
10	DB6	H/L	Data Bus Line
11	DB7	H/L	Data Bus Line
12	CS1	H/L	Chip Selection Signal 1 (Active " Low")
13	CS2	H/L	Chip Selection Signal 2 (Active " Low")
14	RST	H/L	Reset (Active " Low")
15	RW	H/L	Data read / write
16	RS	H/L	Register select signal
17	E	H/L	Enable signal
18	Vout	-10V	Output Voltage for LCD Driving
19	A	(+5.0v)	Power supply for BL LED(+)
20	K	(-)	Power supply for BL LED(-)

9 Block diagram

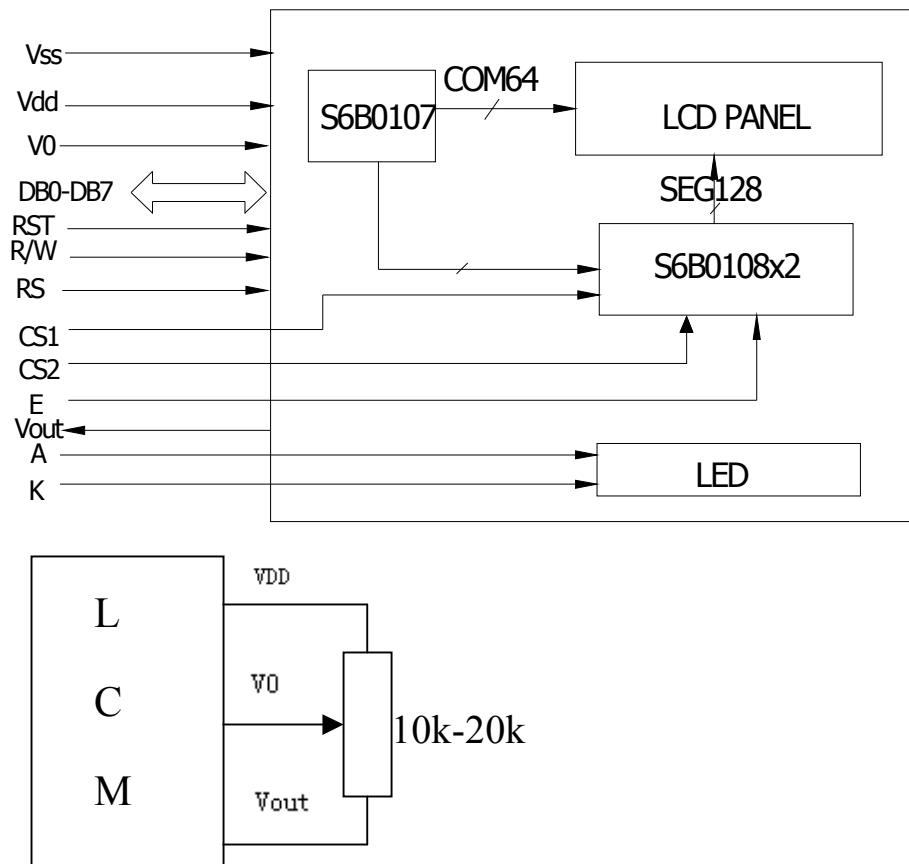

10. Interface Timing Chart

Characteristic	Symbol	Min	Typ	Max	Unit
E Cycle	t_C	1000	-	-	ns
E High Level Width	t_{WH}	450	-	-	ns
E Low Level Width	t_{WL}	450	-	-	ns
E Rise Time	t_R	-	-	25	ns
E Fall Time	t_F	-	-	25	ns
Address Set-Up Time	t_{ASU}	140	-	-	ns
Address Hold Time	t_{AH}	10	-	-	ns
Data Set-Up Time	t_{DSU}	200	-	-	ns
Data Delay Time	t_D	-	-	320	ns
Data Hold Time (Write)	t_{DHW}	10	-	-	ns
Data Hold Time (Read)	t_{DHR}	20	-	-	ns

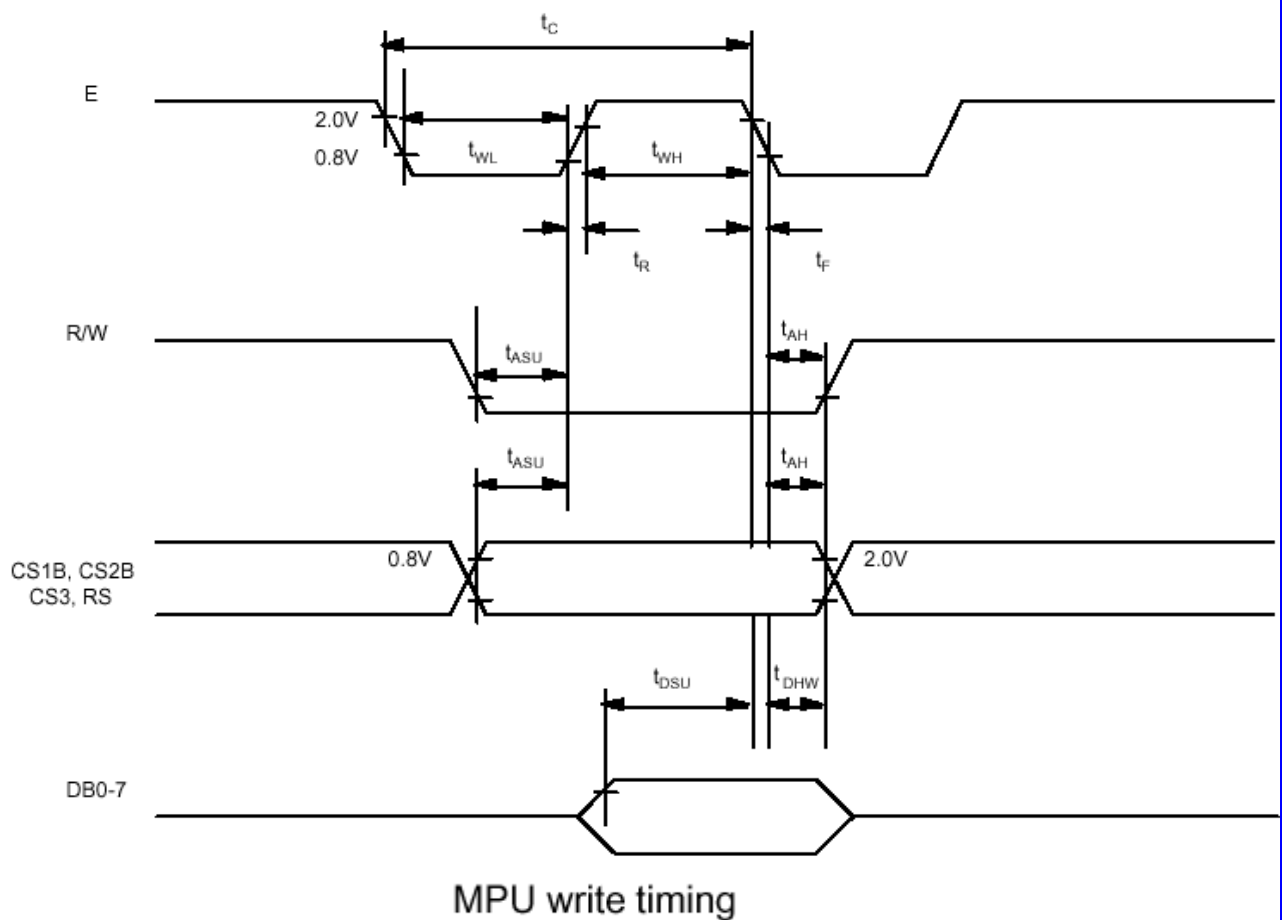

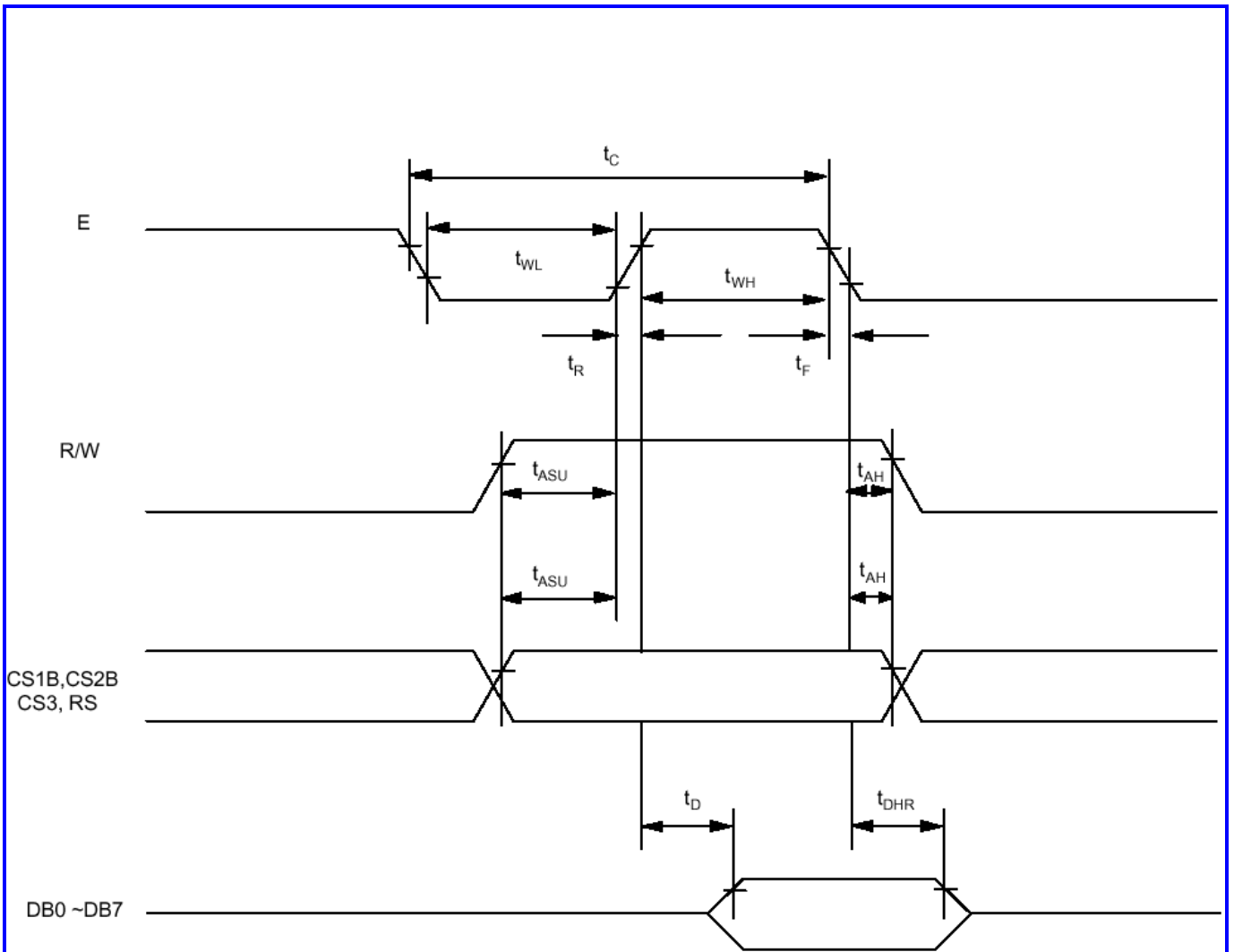

. MPU Read timing

11. Instruction Code

Instruction	RS	R/W	DB7	DB6	DB5	DB4	DB3	DB2	DB1	DB0	Function	
Display ON/OFF	L	L	L	L	H	H	H	H	H	L/H	Controls the display on or off. Internal status and display RAM data is not affected. L:OFF, H:ON	
Set Address (Y address)	L	L	L	H	Y address (0~63)						Sets the Y address in the Y address counter.	
Set Page (X address)	L	L	H	L	H	H	H	Page (0~7)			Sets the X address at the X address register.	
Display Start Line (Z address)	L	L	H	H	Display start line (0~63)						Indicates the display data RAM displayed at the top of the screen.	
Status Read	L	H	B U S Y	L	O N / O F F	R E S E T	L	L	L	L	Read status. BUSY L: Ready H: In operation ON/OFF L: Display ON H: Display OFF RESET L: Normal H: Reset	
Write Display Data	H	L	Write Data									Writes data (DB0:7) into display data RAM. After writing instruction, Y address is increased by 1 automatically.
Read Display Data	H	H	Read Data									Reads data (DB0:7) from display data RAM to the data bus.